

UNIVAC 1107

FLYING HEAD-880

Magnetic Drum Subsystem

December, 1961

CONTENTS

1. INTRODUCTION	1-1
2. FUNCTIONAL DESCRIPTION	2-1
Addressing System	2-3
Timing, Control, and Parity	2-4
3. MAGNETIC DRUM SUBSYSTEM	3-1
FH-880 Magnetic Drum Control Unit	3-2
Channel Synchronizer	3-2
Data Word	3-2
Function Word	3-2
Identifier Word	3-2
Status Word	3-3
Synchronizer-Control Unit Communications	3-4
Drum Subsystem Repertoire	3-6

1. INTRODUCTION

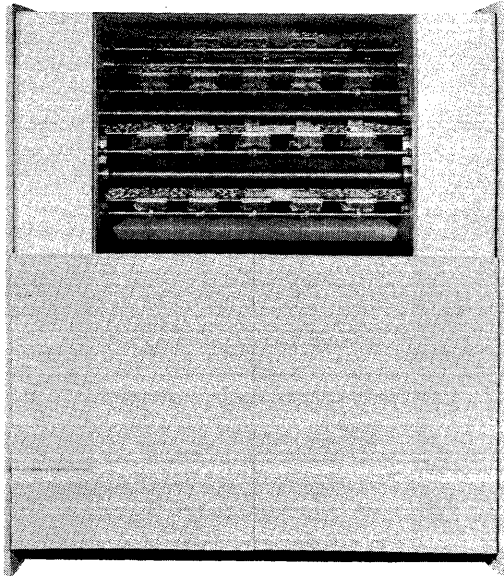

Figure 1-1. The Flying Head 880 Magnetic Drum Unit

The Flying Head 880 (FH-880) magnetic drum is a large capacity, random-access data storage device that presents decided advantages over the conventional or fixed head magnetic storage drum. The FH-880 drum differs from conventional magnetic drums in that the read-write head blocks are supported aerodynamically; the head blocks float on a boundary layer of air generated by drum rotation.

The major advantages of the flying head drum over the conventional or fixed head drum are the following:

- Larger diameter drums can be used.
- Drum tolerances are less critical because the flying head automatically adapts to irregular contours on the drum surface.
- Greater storage density is achieved because the heads are closer to the drum surface.
- Smaller magnetizing currents are permitted because of the close head-to-drum spacing.

2. FUNCTIONAL DESCRIPTION

Binary information is written on and read from the oxide surface of the magnetic drum by the flying read-write heads. These heads are supported by the boundary layer of air flowing around the drum surface. This layer of air is created by drum surface friction which drags air molecules along as the drum rotates at a speed of 1,800 revolutions each minute.

Forty head blocks are mounted on eight head mounting assemblies (five head blocks per assembly) which are equally spaced around the circumference of the drum. Since each flying head block contains 22 read-write heads, there are 880 heads in all. Each head is associated with only one path or track around the drum.

There are 128 six-track data recording bands or channels across the drum which account for a total of 768 data tracks. Some of the remaining tracks are categorized as spares, while others are used for parity, reference, and timing functions.

Each drum is considered to be divided into three angular sections which are numbered sequentially beginning with angular section numbers 0, 1, and 2 for drum number 0 (the first drum of the subsystem) and continuing through angular section numbers 21, 22, and 23 for drum number 7 (the last or eighth drum of the subsystem). These angular sections do not occupy fixed angular positions on the drum. Instead, each angular section is divided into 2,048 separate angular segments. As shown

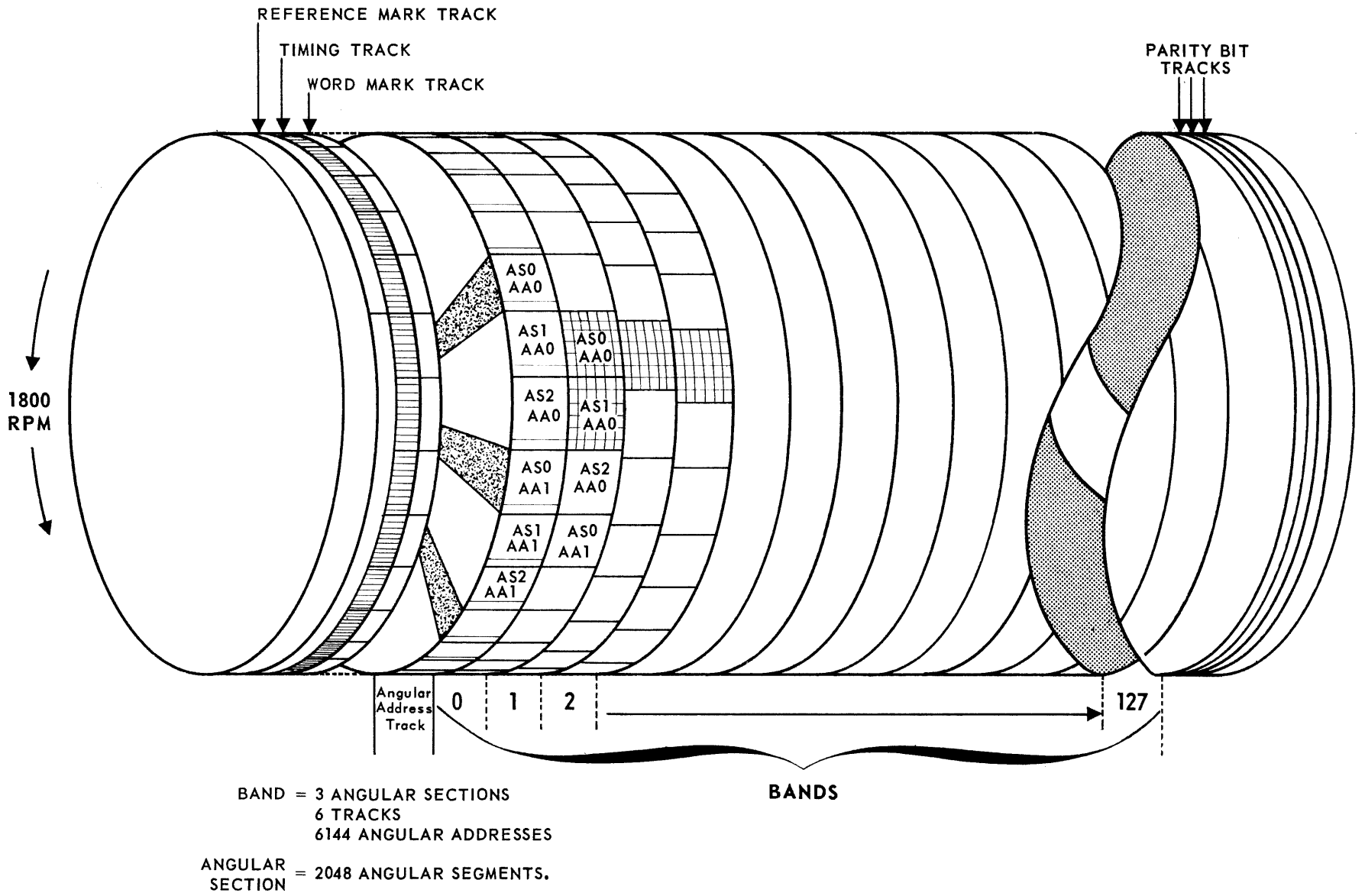

Figure 2-1. FH-880 Magnetic Storage Drum Addressing System

in Figure 2-1, for example, the segments of Angular Section number 0 are spread radially around the band. It should also be noted that the positions of the angular segments vary from band-to-band; that is, because of the parity tracks, corresponding angular segments are not on the same horizontal level across the drum.

On each band there is a full complement of Angular Addresses (2048) associated with each angular section. Each angular address designates a storage area for one 36-bit UNIVAC®1107 computer word. Since there are three angular sections on each band, a total of 6,144 angular addresses occupy each band. Thus, the 128 bands allow a total drum storage capacity of 786,432 words. A subsystem of eight drums provides a total storage capacity of 6,291,456 words.

ADDRESSING SYSTEM

Figure 2-1 shows how information is stored on the drum surface in word units of 36 bits, in a six-by-six-bit matrix. The specific storage location of each word stored on the drum is associated with a particular: angular address number (AA0 through AA2047); band number (0 through 127); and angular section number (0 through 23). This addressing system provides maximum storage with continuous addressability.

A total of 23 binary digit positions are used for specifying a word location on a magnetic storage drum unit. These bit position designators are contained in bit positions 0 through 22 of a special magnetic drum subsystem instruction word which is called a Function Word. As illustrated in Figure 2-2, bit positions 0 through 10 designate the angular address number; bit positions 11 through 17 specify a band number; and the remaining five bit positions, 18 through 22, designate an angular section number (which, in effect, specifies a particular drum unit in the subsystem).

Function Code		Angular Section Number		Band Number		Angular Address Number	
		0-23		0-127		0-2047	
35	30	22	18	17	11	10	0

Figure 2-2. Function Word - Drum Addressing Bit Designators

The designation of a particular magnetic drum storage address by the 23 bit position designators is demonstrated by the following example.

The uppermost angular address number of any band is:

$$2047_{10}^* = 3777_8^* = 11\ 111\ 111\ 111\ (\text{binary})$$

The uppermost band number on any drum is:

$$127_{10} = 177_8 = 1\ 111\ 111\ (\text{binary})$$

The highest angular section number is

$$23_{10} = 27_8 = 10\ 111\ (\text{binary})$$

Combining these three individual bit patterns into bit position designators 0 through 22 and grouping in sets of three for octal interpretation gives:

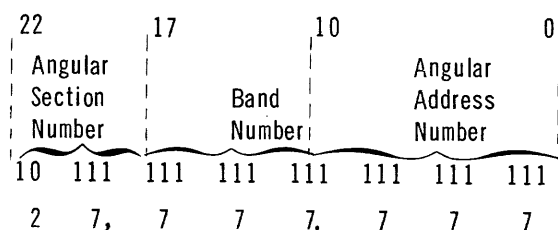

This pattern represents, in octal notation, the uppermost storage address on drum number 7 of the subsystem.

As a practical matter, however, the programmer is not concerned with the bit position designators of the addressing system because he need specify drum addresses in octal notation only. The range of addresses (in octal) for each drum on an eight drum subsystem are presented in the following table.

DRUM	ADDRESSES	
	BEGINNING	ENDING
0	00,000,000	02,777,777
1	03,000,000	05,777,777
2	06,000,000	10,777,777
3	11,000,000	13,777,777
4	14,000,000	16,777,777
5	17,000,000	21,777,777
6	22,000,000	24,777,777
7	25,000,000	27,777,777

* The subscript 10 indicates decimal notation; the subscript 8 indicates octal notation.

Reading or writing in consecutive addresses will begin at the address specified and proceed sequentially to the next angular address, and so on, until angular address 2,047 is reached. The next word will be read or written in angular address 0000 of the next higher band. When band number 127 is reached, the next word will be written or read in band 000, angular address 0000, of the next angular section.

TIMING, CONTROL, AND PARITY

In addition to the tracks associated with the 128 data bands, there are various other tracks on the drum which are used for timing and referencing purposes (Figure 2-1).

The reference mark track contains a single mark which establishes the start of a drum revolution. All other drum timing is referenced to this mark. The timing track contains 36,912 marks, the first of which is coincident with the reference mark. The timing marks establish that a maximum of 36,912 bits can be stored on any track. The word mark track has 6,152 word marks which provide references for storing data in groups of 6 bits.

A parity bit is written on a parity track immediately following each word in the associated data band. There are 32 parity tracks on the drum. Each track stores the parity bits associated with four data bands.

3. MAGNETIC DRUM SUBSYSTEM

A Magnetic Drum Subsystem consists of from one to eight FH-880 magnetic drum units, a FH-880 Control Unit, and a Channel Synchronizer. The Channel Synchronizer and the Drum Control Unit are housed in a single cabinet. Data flow between a magnetic drum and the Computer is routed through the Control Unit and the Channel Synchronizer. Through the use of commands from the Computer and timing and address data from the drums, the Control Unit controls the flow of information between the Computer and the Magnetic Drum Units.

A Magnetic Drum Subsystem is connected to the UNIVAC 1107 Computer through an input-output channel. There are 16 input-output channels. Since one input-output channel is normally assigned to the Control Console, the Computer could well accommodate 15 magnetic drum subsystems. And if each subsystem had its full complement of eight drum units, there would be a total configuration of 120 magnetic drums. Such a configuration represents an enormous data storage capacity.

From an applications standpoint, however, a typical UNIVAC 1107 Computer System configuration would probably use two Magnetic Drum Subsystems. For example, one subsystem of two drums would be used for storing the computer program while the other Magnetic Drum Subsystem of perhaps four or five drums would be used to provide storage for input-output data.

The interrelationships of the various units of the magnetic drum subsystem are presented in Figure 3-1.

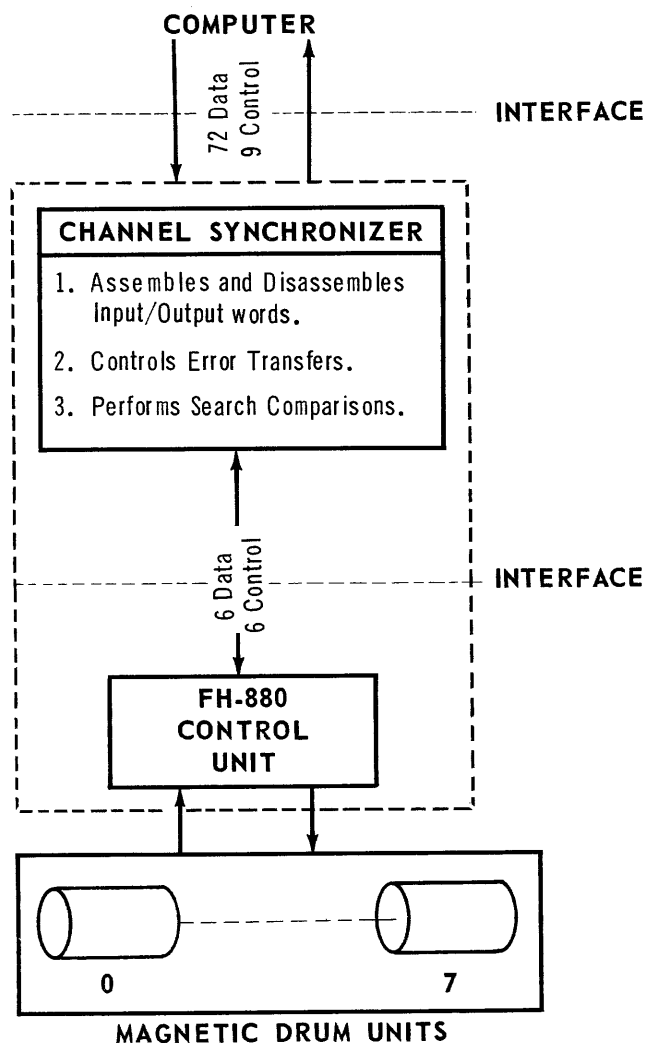

Figure 3-1. Magnetic Drum Subsystem

FH-880 MAGNETIC DRUM CONTROL UNIT

The FH-880 Magnetic Drum Control Unit controls the flow of information between the magnetic drum units and the Channel Synchronizer. It accepts 6-bit output data characters from the Channel Synchronizer and distributes them to the drum units as specified by the computer program. The Drum Control Unit also transmits the 6-bit input data characters (received from the drum units) to the Channel Synchronizer.

CHANNEL SYNCHRONIZER

As shown in Figure 3-1, the Channel Synchronizer provides an interface, common electrical and logical boundary, between the Computer and the FH-880 Drum Control Unit.

During an output operation (Computer to Drum Control Unit), the Channel Synchronizer stores the 36-bit computer word in its Assembly-Disassembly Register. Then, when the Control Unit is ready to receive the data, the Channel Synchronizer disassembles the 36-bit word into six 6-bit characters for transfer to the Control Unit. During input data transfers, the Channel Synchronizer assembles the six 6-bit characters received from the Control Unit into 36-bit words for transmission to the Computer. In effect, the Channel Synchronizer serves as a medium of storage during input-output transfers of data between the Computer and the Magnetic Drum Control Unit.

In addition to the assembling and disassembling of data words, the Channel Synchronizer performs two other functions: error transfers and search comparisons. The error transfer function is described under the heading *Status Word*, page 3-3, and the search comparison activity of the Channel Synchronizer is described in the explanation of the *Search* function of the *Drum Subsystem Repertoire*, page 3-6.

The Channel Synchronizer handles four types of words which are used in connection with the Magnetic Drum Subsystem.

Data Word

The Data Word (input or output) is arranged in groups of six-bit characters.

Most Significant Character	DATA WORD						Least Significant Character				
6	5	4	3	2	1						
35	30	29	24	23	18	17	12	11	6	5	0

The assembling and disassembling of Data Words by the Channel Synchronizer is described above.

Function Word

The Function Word contains operating instructions for the subsystem drum units. The instructions are in the form of a function code which is contained in bit positions 30 through 35 of the Function Word.

As explained under the *Addressing System*, page 2-3, bit positions 0 through 22 of the Function Word specify a particular address location on a specific drum unit.

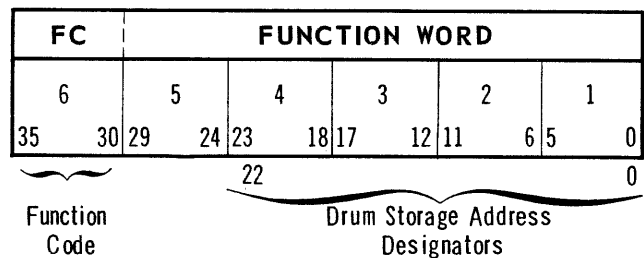

A Function Word must be sent to the Channel Synchronizer before any type of input, output, or special operation is initiated. A Function Word is always accompanied by an external function signal to distinguish it from a Data Word. Upon receiving a Function Word, the Channel Synchronizer decodes the function code bits which set the operating mode for the Channel Synchronizer. The Magnetic Drum Control Unit also uses the function code to direct the operation of individual drum units of the subsystem.

The various function codes of the Function Words are explained under the *Drum Subsystem Repertoire*, page 3-6.

Identifier Word

The Identifier Word is a 36-bit word which is transmitted immediately after a Function Word containing a Search or Search-Read function code. Like the Function Word, the Identifier Word is also accompanied by an external function signal when it is transmitted to the Channel Synchronizer by the Computer. The Identifier Word is stored in the

Assembly-Disassembly Register of the Synchronizer and compared character-by-character with each searched word.

IDENTIFIER WORD											
6		5		4		3		2		1	
35	30	29	24	23	18	17	12	11	6	5	0

Status Word

The Status Word contains the error information generated by the FH-880 Control Unit and the Channel Synchronizer. This information is contained in bit positions 30 through 35, the status or error code. Bit positions 32 through 35 are commonly referred to as the interrupt code.

SC	STATUS WORD											
6	5		4		3		2		1			
35	30	29	24	23	18	17	12	11	6	5	0	
				22								0
Status (Error) Code				Overflow Address and Error Word Address								

Bit positions 0 through 22 of the Status Word contain the overflow addresses and the error word address. This allows an error to be located at a particular location, on a particular drum.

Actual coding of the Status Word begins at the Magnetic Drum Control Unit. The Status Word is then sent to the Channel Synchronizer. If the Channel Synchronizer has any error information, it is added to the Status Word. When the Channel Synchronizer has accumulated all the error information, it sends an interrupt signal to the Computer.

The following is a list of the various status (error) codes that can be generated by the Magnetic Drum Control Unit and the Channel Synchronizer.

STATUS CODE (OCTAL)	DESCRIPTION OF ERROR
06	Drum Error Indication
07	Drum Error Address
20	Channel Synchronizer Sequence or Operational Error
30	Channel Synchronizer Character-Count Error
50	Illegal Function Code
54	Illegal Address on Unit Selection
64	Parity Error or Drum
70	Control Unit Character-Count Error.
74	Interlock Fault (requires manual intervention)

Other codes generated by interrupts and contained in the upper six bit positions of the Status Word include:

04	Drum Overflow Address (word following end-of-block word)
05	Drum Search Find Word
34	End-of-Block (information)
40	Normal Answer to a Function Requesting an Interrupt

A brief explanation of some of the Status Word error conditions follows:

Parity each word of data is recorded with odd parity. If an even parity is detected during a read operation, a parity error interrupt is transmitted to the Computer.

Character Count whenever any character of a word is not transferred to or from the drum, a character count error interrupt is transmitted to the Computer.

Illegal-Invalid Addresses any address that is not available when referenced by a Function Word is an Illegal Address.

any address that is not available when referenced during an operation is an Invalid Address.

Illegal Function any operation code included in a Function Word which is not included in the Magnetic Drum Subsystem repertoire causes an illegal function interrupt to be transmitted to the Computer.

SYNCHRONIZER-CONTROL UNIT COMMUNICATIONS

A block diagram of major registers and lines relating to transfers of control signals and data between the Channel Synchronizer and the FH-880 Magnetic Drum Control Unit is shown in Figure 3-2.

The following information pertains to the sequence of events that takes place during communications between the Channel Synchronizer and the Drum Control Unit. It is assumed that the Drum Control Unit is in a cleared condition.

FUNCTION

DESCRIPTION

External Synchronizer transfers the function code character of the Function Word to the Control Character Register of the Control Unit.

Synchronizer sends the External Function signal to the Control Unit via the External Function Line.

The Control Unit detects the External Function signal, samples the contents of its Character Register, and then transfers the contents of the Character Register to the Function Code Register.

The Control Unit sends a Ready signal to the Channel Synchronizer via the Ready Line.

The Control Unit discards the second character of the Function Word since it contains no usable data (bit positions 2₂₉ - 2₂₄). The remaining three characters contain drum addressing information.

If no data transfer is indicated by the function code, the sequence is ended. If either an input or an output data

Input

transfer is indicated by the function code, the sequence of events continues as follows:

If an input data transfer is specified by the function code, the Channel Synchronizer sends a Resume signal to the Control Unit.

The Control Unit detects a Resume signal and initiates an external operation.

The Control Unit transfers a character of data to the Character Register of the Channel Synchronizer and then sends a Ready signal to the Channel Synchronizer.

The Channel Synchronizer detects the Ready signal, samples its Character Register, and then transfers the contents of its Character Register to the Assembly-Disassembly Register.

The Channel Synchronizer sends a Resume signal to the Control Unit.

Repeat above steps until end of input data or termination by interrupt.

Output

If an output data transfer is specified by the function code, the Channel Synchronizer transfers a character of output data to the Control Unit Character Register and sends a Resume signal to the Control Unit.

The Control Unit detects the Resume signal; initiates an external operation; samples and clears its Control Character Register; and sends a Ready signal to the Channel Synchronizer.

The Channel Synchronizer detects the Ready signal; sends a character of output data to the Control Character Register of the Control Unit; and then sends a Resume signal to the Control Unit.

Repeat above steps until end of output data at which time instruction will be terminated by the Computer.

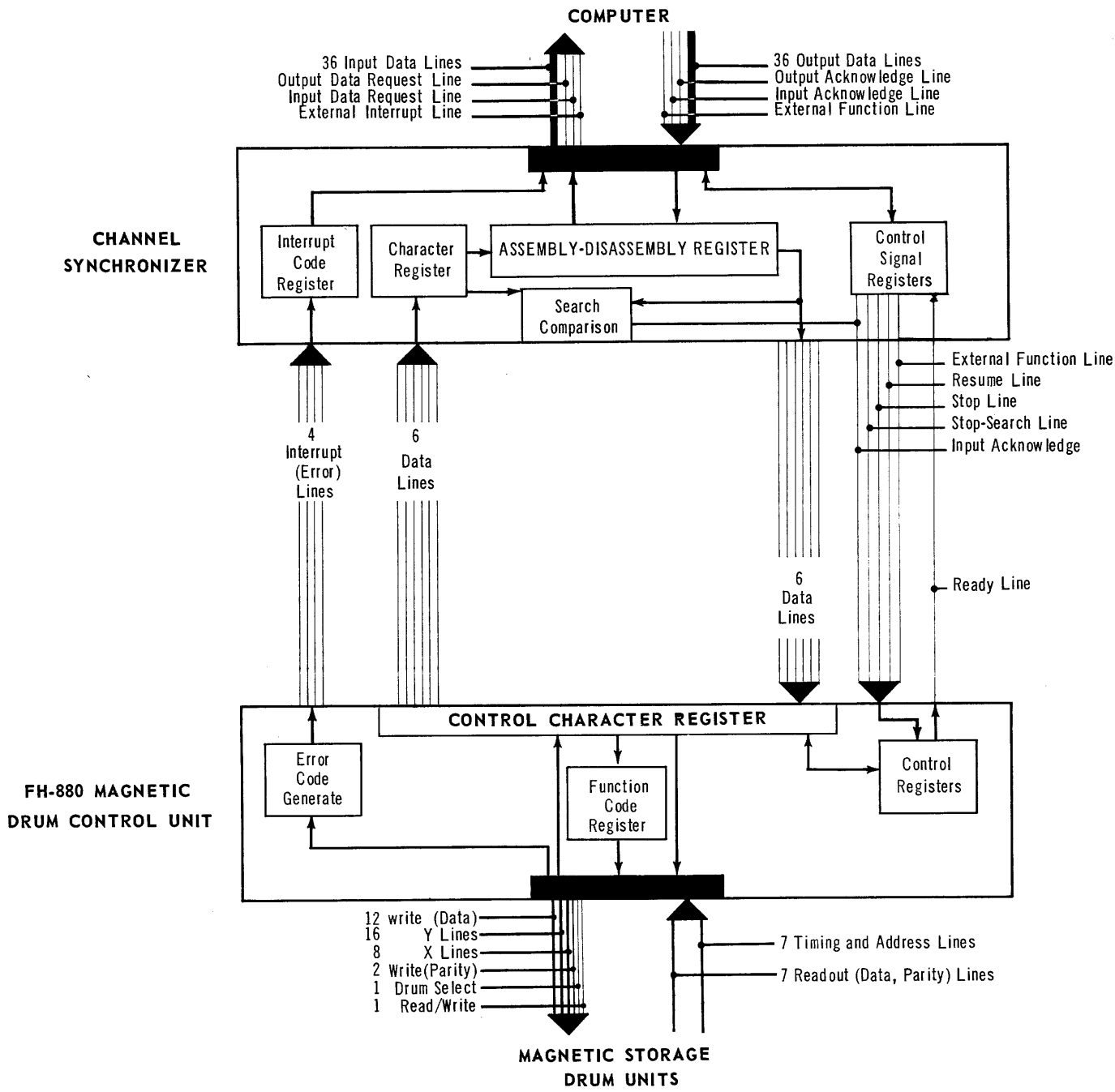

Figure 3-2. Block Diagram - Synchronizer and Control Unit

DRUM SUBSYSTEM REPERTOIRE

The following operations are performed by the Magnetic Drum Subsystem. (As mentioned previously, the function codes are stored in the most significant character portion of the Function Word.)

Continuous Write (02)

Begin writing information from the address specified in the Function Word and continue through successive drum addresses until the last drum address is reached, or a terminate function is encountered, or character-count error is detected, or terminated by an interrupt.

Continuous Read (42)

Begin reading information from the magnetic drum address specified in the Function Word and continue through successive drum addresses until the last drum address is reached, or a terminate function is encountered, or a parity or character count error is detected, or an interrupt occurs.

Block Read (52)

Begin reading input data from the magnetic drum address specified in the Function Word and continue through successive drum addresses until one of the following occurs: the last drum address is reached, a terminate function is encountered, a parity or character-count error is detected, or the End-of-Block sentinel (a word of all binary 1's) is read, or an interrupt occurs.

Search (45)

The search operation cannot begin until an Identifier Word (any full length computer word) is transferred to the Channel Synchronizer and stored in this unit's Assembly-Disassembly Register. The Identifier Word is then compared bit-by-bit with information read from the drum.

Searching begins at the drum address specified in the Function Word and continues through successive drum addresses until one of the following occurs: a find occurs, a terminate function is encountered, the last drum address is reached, or a parity or character-count error is detected, or an Interrupt containing a find address occurs, or another interrupt occurs.

The block search function is the same as the search operation except that an End-of-Block word terminates the search if the search is not terminated by an interrupt containing a find address.

Search Read (46)

The search read operation is actually a combination of a search and continuous read function. The search portion begins at the drum address specified in the Function Word and continues as bit-by-bit comparisons with the identifier are made with successive drum addresses. When a find occurs, the continuous read operation begins and continues through successive drum addresses until the last drum address is reached, or a terminate function is given, or a parity or character count error is detected.

If a find does not take place, the search of successive addresses continues until one of the following occurs: a terminate function is given or a parity or character-count error is detected.

Block Search Read (56)

The block search read function is the same as the search read operation except that after an End-of-Block word is detected, one more word is transmitted to the Computer. This word can be an overflow address or the next link in a chain of data.

Terminate (23)

The terminate function signals the end of the current operation. As soon as the Data Word is transferred to the drum surface all transfers stop. The transfer stops immediately if the Data Word is being transferred from the magnetic storage drum.

Initial Load (Bootstrap) (40)

The initial load function is actually a combination operation. When this function is issued, the Magnetic Drum Subsystem terminates the current operation and begins a continuous read operation from octal address 0 of the Magnetic Drum Subsystem, regardless of any address specified in the function word.

Remington Rand Univac
DIVISION OF SPERRY RAND CORPORATION